



Post Office Box 322
Willow Spring, NC 27592-9998





Bog Hog Mud Motors are powered by air-cooled Kohler® or Briggs & Stratton® engines available from 5 to 25 horsepower. These specially designed motors allow you to travel through areas of heavy vegetation, mud, and obstruction-laden waters. The four stroke engines are dependable, low maintenance and have a reputation for long life.



Please note the design highlights listed below. Used models are also available. Give us a call if you have further questions or want to own a tough mud motor that is easy on your finances.

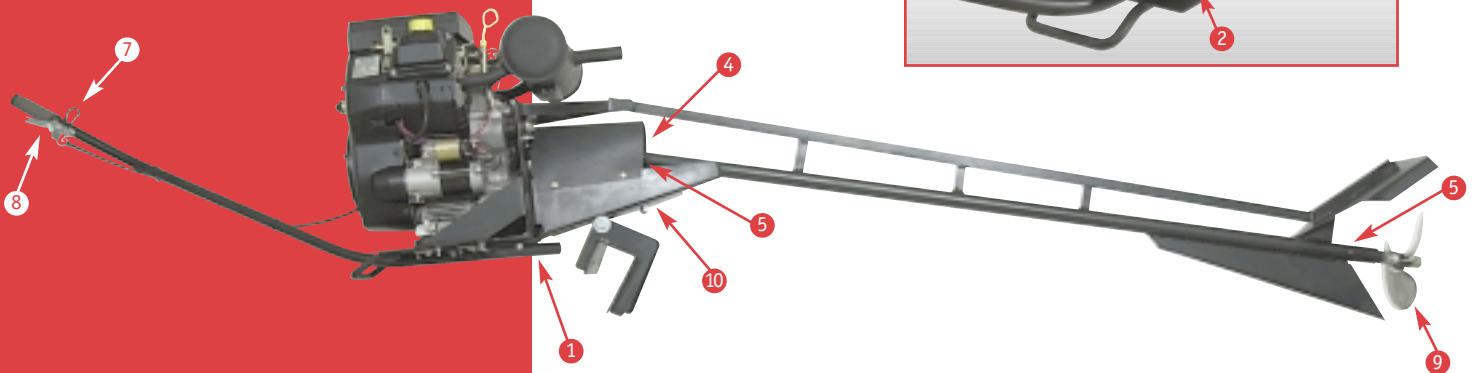
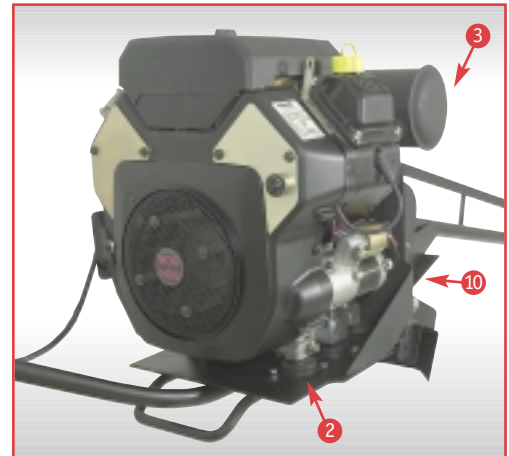

- 1 Formed Frame Components. Unlike the piece-wise construction method used by other brands, Bog Hog has a unitized frame for improved strength to weight ratio.
- 2 Engine Isolation. Bog Hog Mud Motors have rubber isolated engines for lower noise and vibration levels.
- 3 Extra-large muffler and muffler guards (*not shown*) for quiet, safe operation.
- 4 Fully enclosed universal joint cover for safety.
- 5 Individually greasable oil impregnated bronze bushings.
- 6 One coat of primer and two coats of marine grade acrylic paint.
- 7 Operator presence switch.
- 8 True one hand operation with integrated throttle lever and handle bar grip.
- 9 Two blade stainless steel cupped propeller.
- 10 Greaseless steering mechanism.

(866) 264-4647
sales@boghogmudmotors.com

Post Office Box 322
 Willow Spring, NC 27592-9998